

Acoustic Sensors

SITRANS AS100

Operating Instructions · 05/2013



SITRANS

SIEMENS

Safety Guidelines: Warning notices must be observed to ensure personal safety as well as that of others, and to protect the product and the connected equipment. These warning notices are accompanied by a clarification of the level of caution to be observed.

Qualified Personnel: This device/system may only be set up and operated in conjunction with this manual. Qualified personnel are only authorized to install and operate this equipment in accordance with established safety practices and standards.

Unit Repair and Excluded Liability:

- The user is responsible for all changes and repairs made to the device by the user or the user's agent.
- All new components are to be provided by Siemens Milltronics Process Instruments.
- Restrict repair to faulty components only.
- Do not reuse faulty components.

Warning: Cardboard shipping package provides limited humidity and moisture protection. This product can only function properly and safely if it is correctly transported, stored, installed, set up, operated, and maintained.

This product is intended for use in industrial areas. Operation of this equipment in a residential area may cause interference to several frequency based communications.

Note: Always use product in accordance with specifications.

Copyright Siemens AG 2013. All Rights Reserved

Disclaimer of Liability

This document is available in bound version and in electronic version. We encourage users to purchase authorized bound manuals, or to view electronic versions as designed and authored by Siemens Milltronics Process Instruments. Siemens Milltronics Process Instruments will not be responsible for the contents of partial or whole reproductions of either bound or electronic versions.

While we have verified the contents of this manual for agreement with the instrumentation described, variations remain possible. Thus we cannot guarantee full agreement. The contents of this manual are regularly reviewed and corrections are included in subsequent editions. We welcome all suggestions for improvement.

Technical data subject to change.

MILLTRONICS® is a registered trademark of Siemens Milltronics Process Instruments.

Contact SMPI Technical Publications

at the following address:

Technical Publications
Siemens AG
Siemens Milltronics Process Instruments
1954 Technology Drive, P.O. Box 4225
Peterborough, Ontario, Canada, K9J 7B1
Email: techpubs.smpi@siemens.com

European Authorized Representative

Siemens AG
Industry Sector
76181 Karlsruhe
Deutschland

- For a selection of Siemens Milltronics level measurement manuals, go to: **www.siemens.com/processautomation**. Under Process Instrumentation, select *Level Measurement* and then go to the manual archive listed under the product family.
- For a selection of Siemens Milltronics weighing manuals, go to: **www.siemens.com/processautomation**. Under Weighing Technology, select *Continuous Weighing Systems* and then go to the manual archive listed under the product family.

Table of Contents

General Information	1
SITRANS AS100 Sensor	1
Features	1
Specifications	2
Outline and Dimensions	4
Installation	7
Ideal Locations	7
Conditions to Avoid	7
Conditions to Consider	7
Mounting	8
Temperature Considerations	11
Interconnection	12
SITRANS AS100 Standard Temperature Version (ST)	12
Extended Temperature Version (ET)	12
Analog Output	13
Relative Sensitivity	13
Applications	14
Pneumatic Conveyor	14
Screw Conveyor Discharge	14
Diverter Gate	14

General Information

SITRANS AS100 Sensor

SITRANS AS100 is an acoustic sensor for flow detection. It monitors high frequency acoustic emissions (sound waves) generated by:

- the friction and impact of solids flow in pipes, chutes, and conveyors
- cavitation occurring in pumps, pipes, and valves
- turbulence of gases or liquids leaking through valves and flanges
- friction and jarring of mechanical parts

Acoustic emissions travel readily through solid materials such as metal, but are strongly attenuated when traveling through air. As such, the Sensor is immune to airborne interferences and provides a non-invasive method of monitoring process activities.

The sensor can be configured electrically during wiring to operate in either low or high sensitivity range mode. The high sensitivity range applies where highest signal levels vary up to 40 dB. The low sensitivity range applies where highest signal levels vary between 28 and 68 dB.

SITRANS AS100 Sensor provides an analog output for use with the Sitrans Control Unit. The Sensor may be operated independently from the Control Unit by providing an external supply. The output is fed into a control panel, chart recorder, data logger, or programmable logic controller with a suitable input.

SITRANS AS100 Sensor is primarily used for solids flow detection. However, this device can be used in pump cavitation and fluid leak detection, provided sufficient noise levels are generated.

Notes:

- The SITRANS AS100 is to be used only in the manner outlined in this manual
- This product is intended for use in industrial areas. Operation of this equipment in a residential area may cause interference to several frequency based communications.

Features

- non-invasive
- screw in, bolt on, weld, or bond in place
- analog output
- high and low sensitivity range of operation

Specifications

Model

- standard standard operating temperature range (see below)
- extended extended operating temperature range (see below)

Power

- 20 to 30 V DC
- 18 mA typical

Operating Temperature

- standard -20 to 80 °C (-4 to 176 °F)¹
- extended: -30 to 120 °C (-22 to 248 °F)² or
-40 to 125 °C (-40 to 257 °F)³

Relative Sensitivity

- 0.5% / °C of reading, average over the operating range

Output

- analog, 0.08 to 10 V DC nominal, 100 K Ω minimum load impedance

Construction

- housing 304 stainless steel
303 stainless steel (CSA/FM Class II, ATEX II 3D version)
aluminum (ATEX II 2GD version)
- cable standard: 4 m (13 ft) cable, PVC jacketed, 3 twisted pairs, 24 AWG, shielded
extended: 4 m (13 ft) cable, thermoplastic elastomer jacketed, 6 conductor, 24 AWG conductor, shielded

Ingress Protection

- IP68 (waterproof) The IP68 test was performed by immersing the enclosure in 1.8 m of water for 30 minutes.

Weight

- 0.4 kg (1 lb.)
- 1.2 kg (2.65 lb.) (ATEX II 2GD version)

1. Available for CSA/FM Class II, ATEX versions

2. Available only for CSA Class II version

3. Not available for hazardous rated versions

Approvals

- General CE, C-TICK, KCC
- Hazardous Europe: ATEX II 2GD
Ex II 2G Ex d IIC T4 Gb
Ex II 2D Ex tb IIC T100 °C Db
DEKRA cert #: DEKRA 13ATEX0006 X
Standards: 60079-0 : 2009, EN 60079-1 : 2007
and EN 60079-31 : 2009
ATEX II 3D
US: FM Class II, Div. 1, Groups E, F, G
Canada: CSA Class II, Div. 1, Groups E, F, G

Outline and Dimensions

SITRANS AS100 (ST and ET versions)

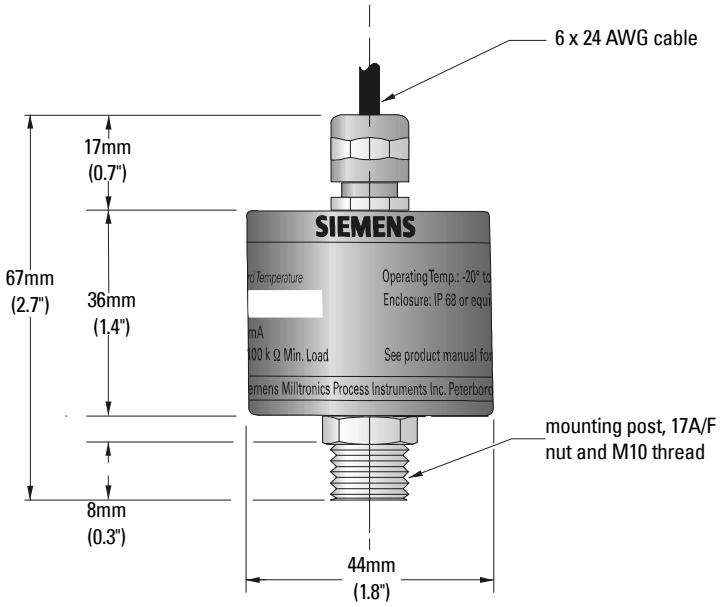

SITRANS AS100 (CSA/FM Class II Rated ST and ET versions)

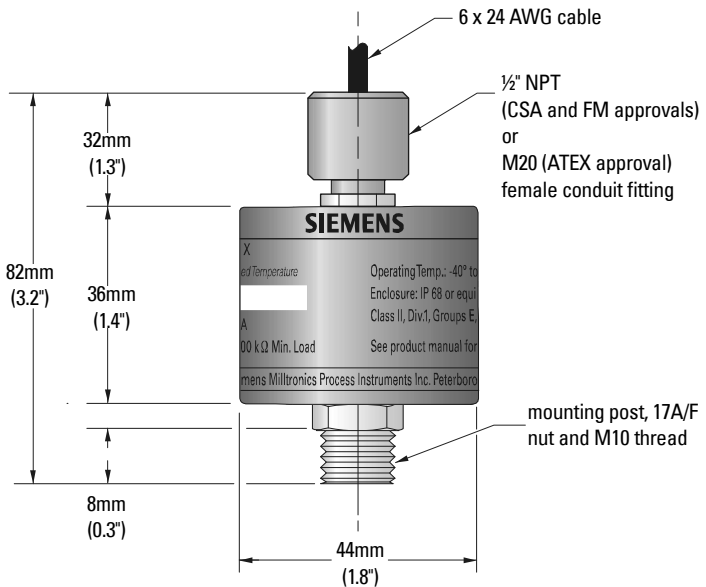

SITRANS AS100 (ATEX II 2GD version)

**Warning: Do not open when an explosive atmosphere is present.
Possible static hazard. Do not rub or clean the product on site.**

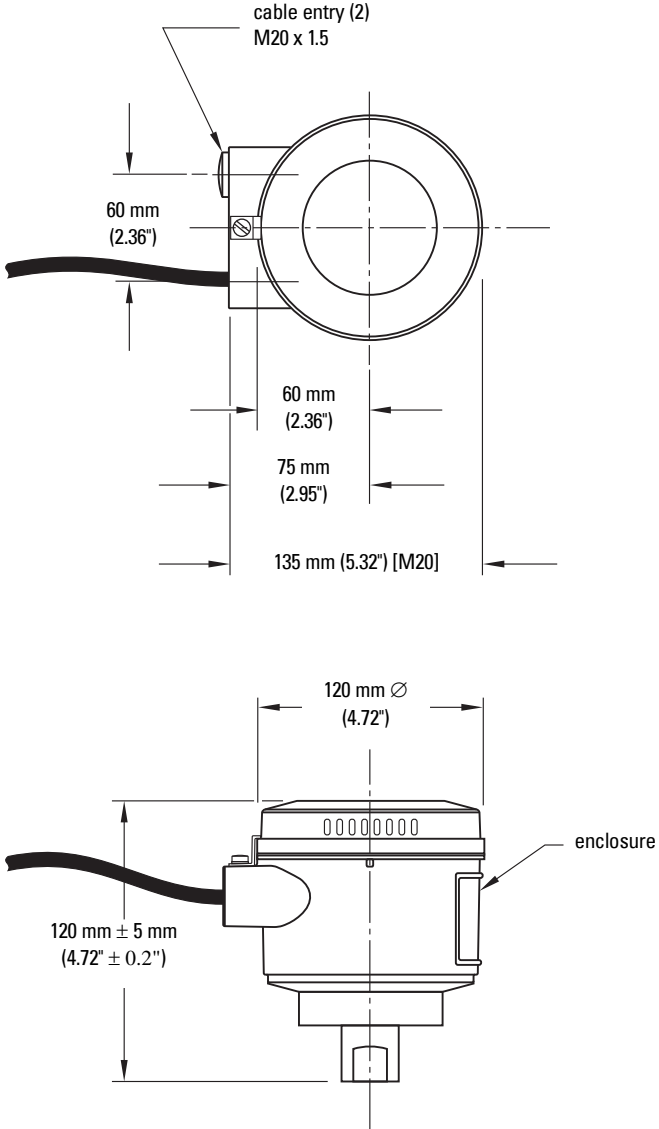

Accessories

Extension Tab (optional, not available for ATEX II 2GD version)

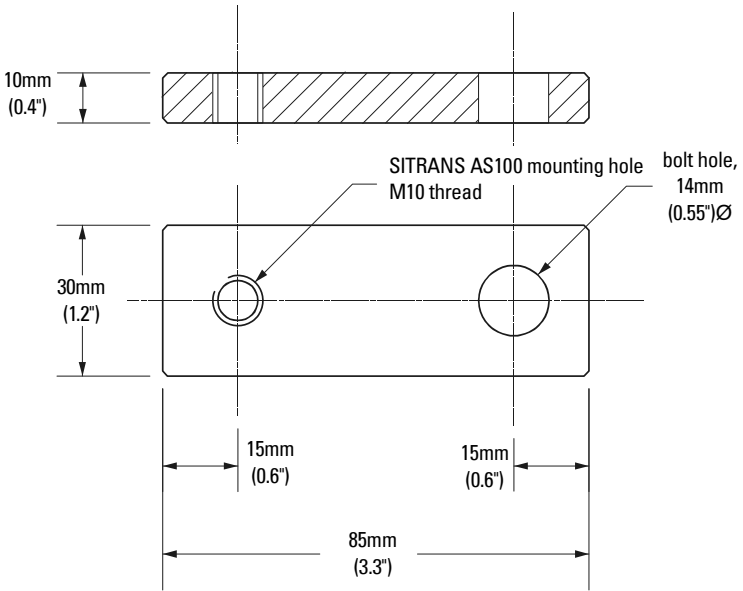

Mounting Disc (optional, not available for ATEX II 2GD version)

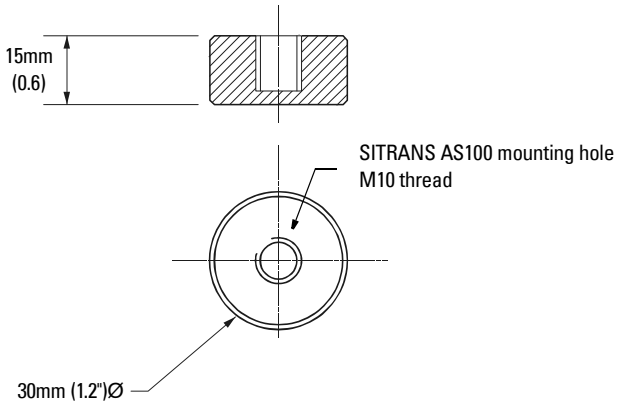

Note: Both Tab and Disc are 304SS.

Installation

Ideal Locations

- areas where the acoustic emission levels are highest and most consistent
- where the material impact is greatest
- areas closest to the point of leakage (e.g. valve body)
- closest point to source of cavitation (e.g. pump body)

Conditions to Avoid

- non-metallic surfaces, as these tend to attenuate acoustic emission levels
- pipes with non-metallic liners as these tend to attenuate acoustic emission levels

Conditions to Consider

- joints and interfaces attenuate the acoustic emission levels.
- minimal temperature variation where acoustic emission levels are weak.
- location should provide sufficient response time in alarm or control circuit. e.g. loss of bearing lubrication, plug chute detection.

Solids Flow Sensing

Recommended

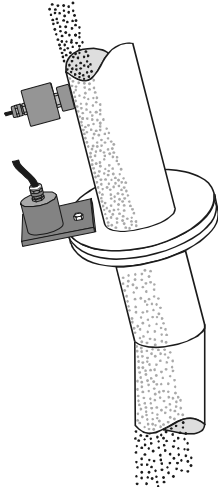

Good friction between product and piping. Mount Sensor on the upstream side of gasket for highest level of acoustic emission activity.

Not Recommended

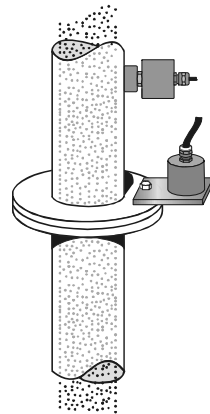

Minimal amount of acoustic emission activity due to limited friction between product and piping.

Mounting

Notes:

- To ensure the most ideal location, test the SITRANS AS100 by clamping the Sensor to the application, and running a trial period to determine the system's performance. The acoustic emission level can be monitored by a voltmeter across the analog output. Refer to Interconnection on page 12.
- Coating the contact surfaces with grease enhances the propagation of acoustic emissions to the Sensor.

Mounting Method	Acoustic Coupling and Sensitivity
Clearance hole	Good
Drill and Tap	Good
Mounting Disc	Good
Extension Tab	Fair

Direct Mounting

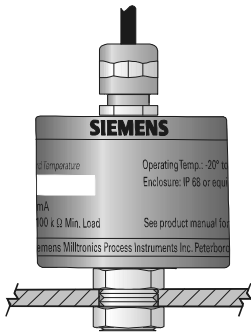

Clearance Hole

Insert mounting post through hole in device being monitored and fasten with customer-supplied washers and nut.

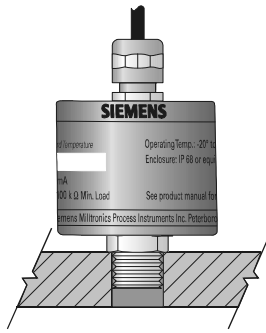

Drill and Tap

Screw mounting post into threaded hole in device being monitored.

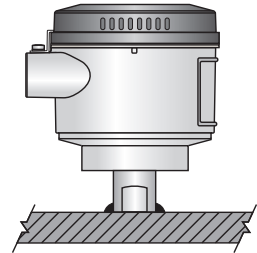

Contact

Weld or bond mounting post to device being monitored. When welding, first remove the acoustic sensor from the housing.

Note: To ensure proper coupling, the face of the Sensor nut must be tight to the application surface.

Accessory Mounting

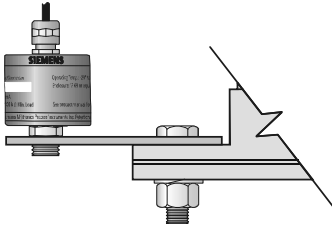

Extension Tab

Screw Sensor into threaded hole of tab, and fasten onto device being monitored.

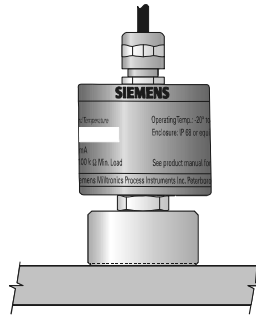

Mounting Disc

Screw Sensor into disc, after welding or bonding disc onto device being monitored.

Notes:

- If welding, weld must be a continuous bead. Tacking does not provide sufficient acoustical coupling.
- Do not arc weld on equipment connected to a SITRANS AS100. Remove the SITRANS AS100 or disconnect electrically to avoid current flowing through the sensor.
- If gluing, use Loctite 326 adhesive, or equivalent. Follow manufacturer's instructions to ensure proper adhesion.

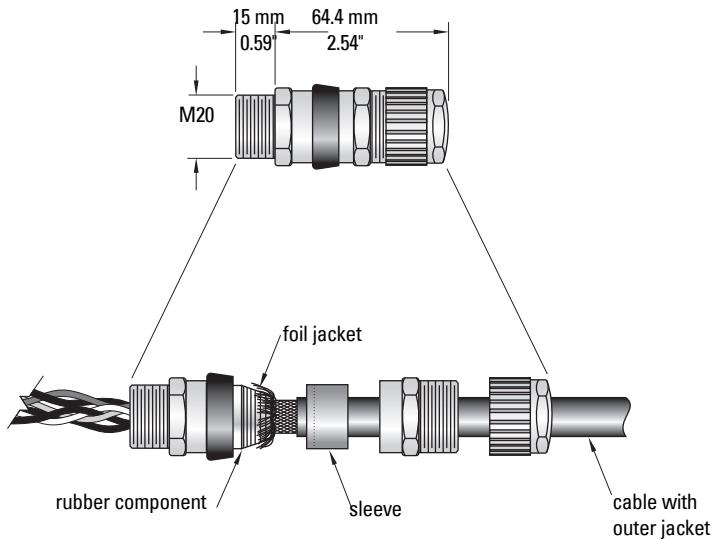

Cable Gland (optional for use with ATEX II 2GD version)

The ATEX II 2GD version is supplied with an approved cable gland. Installation of glands/conduit must conform to local governing codes.

1. Disassemble the cable gland and discard the plastic membrane inside.
2. Route the cable into the M20 section of the gland and thread it onto the housing.
3. Mark the cable 2" (50 mm) from the entry of the housing then remove the acoustic sensor from the housing.
4. Remove the outer jacket of the cable from the acoustic sensor to the mark on the cable.
5. Reinstall the acoustic sensor into the housing and route the cable through the M20 section and into the throat of the rubber component.
6. Peel back the foil jacket (on the cable) over the tapered steel (connected to the rubber component).
7. Install the sleeve over the tapered steel part, and thread the remaining two parts of the gland onto the cable.
8. Tighten the assembly to ensure a seal of the gland over the cable with outer jacket.

Temperature Considerations

Warning: Temperature at Sensor must not exceed minimum or maximum ratings.

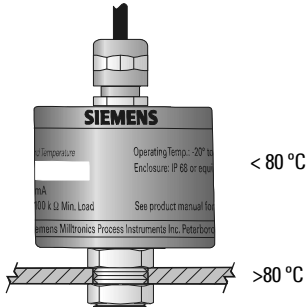

Ensure adequate isolation from hot surfaces by providing additional spacing.

Note: for standard Temperature range model, maximum temperature is 80 °C.

*maximum range dependent on model.

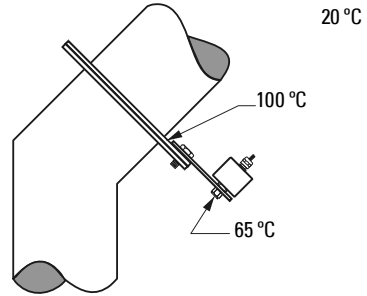

Tab acts as heat sink.

Note: If the flange temperature is 100 °C and the ambient temperature is 20 °C, the Sensor temperature at the electronics is below the maximum rating.

Interconnection

SITRANS AS100 Standard Temperature Version (ST)

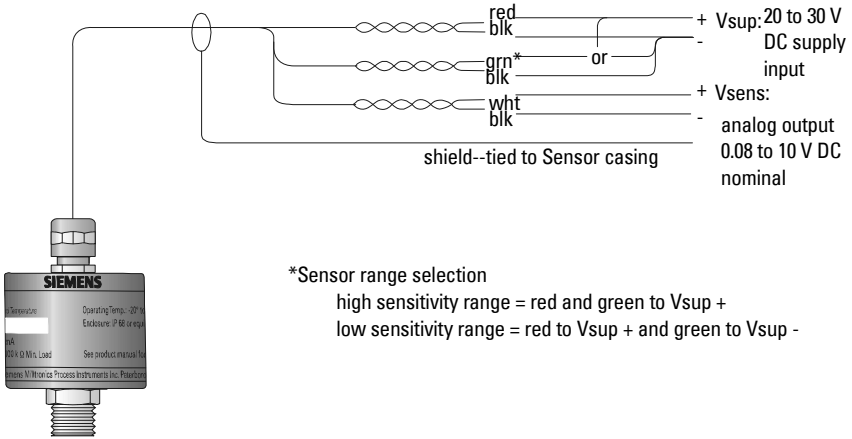

Extended Temperature Version (ET)

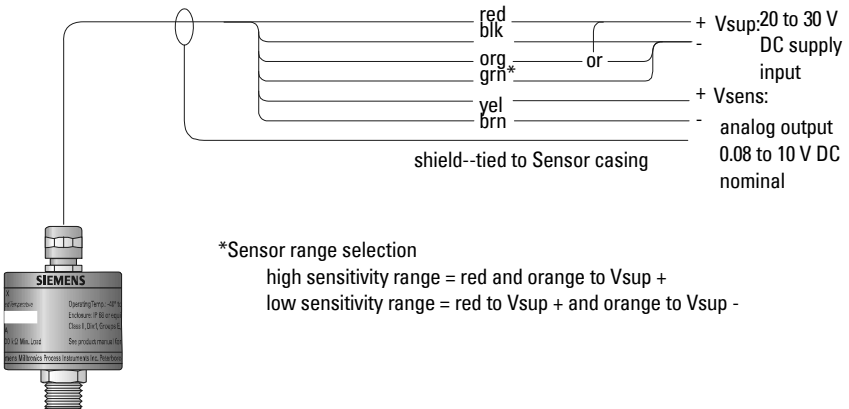

Notes:

- Connect shield to ground at one end only!
- If Sensor mounting is grounded, leave cable shield disconnected
- If Sensor mounting is not grounded, connect cable shield to ground

The longer the cable, the more susceptible it is to noise and earth loops. We recommend using cable with heavy gauge conductors and good RF/electrical shielding (copper braid rather than drain and foil). A proper junction box close to the sensor is an ideal location not only to extend the cable, but to also to configure the wiring for high or low sensitivity range operation.

This table provides a guideline for suitable wire gauges where distances are considerable.

Maximum distance between Sensor and supply (24V or Control Unit)

wire size			distance	
AWG	mm	mm ² *	meters	feet
24	7 x 0.20	0.22	500	1600
22	7 x 0.25	0.35	800	2600
20	10 x 0.25	0.5	1200	3900

* nominal wire size

Analog Output

The Sensor provides an analog output proportional to the level of acoustic emission activity. As the level of acoustic emission activity is a relatively good indication of process or mechanical activity, the output is suitable as an input to devices such as dataloggers chart recorders and programmable logic controllers.

The output is 0.08 to 10V (nominal), dc coupled, short circuit protected with a 60 μ s time constant. The minimum load impedance is 100 K Ω . Refer to Installation on page 7 or Interconnection on page 12.

Relative Sensitivity

The sensitivity of acoustic emission is affected by temperature. In most applications this is not a concern when considering the much greater changes in signal level due to changes in flow. However, it is important to be aware of the effect.

The sensitivity of the SITRANS AS100 Sensor decreases with increasing temperatures at a rate of approximately 0.5% per degree Celsius.

For example, if the temperature of the standard Sensor increased from 20 °C to 50 °C, its sensitivity would decrease by 15%. If the Sensor were to be used to monitor flow changes over such a temperature range, you should set an associated alarm setpoint at least 30% away from the normal operating level measured at 20 °C.

Applications

Pneumatic Conveyor

A tanker load of bulk solid material is being pneumatically conveyed into a silo. The Sensor detects the acoustic emissions generated by the particles impacting against the pipe wall and the output is used to activate the silo dust filter system.

Recommended location is any impact point along the line, such as an elbow.

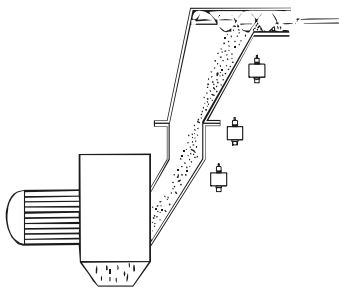
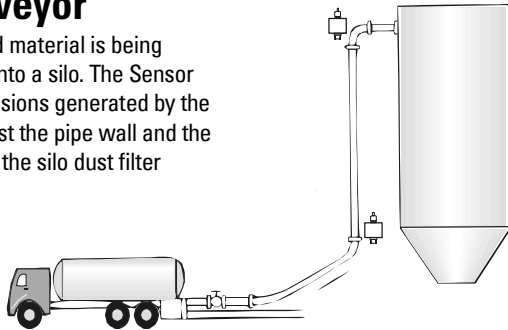

Screw Conveyor Discharge

A fibrous material is being delivered to a pelletiser by means of a screw feeder. When loss of flow is detected by the Sensor, an alarm in the control room informs the operator of a possible blockage.

Recommended location is any point along the under side of chute, where there is friction due to the flow of material.

Diverter Gate

The process material is stored in a hopper and fed into the process through a diverter gate. A Sensor mounted to each leg of the diverter indicates the presence or absence of flow in the open leg. Low alarm gives early indication of problems in the diverter gate or slide gate, or of blockage or material shortage in the hopper.

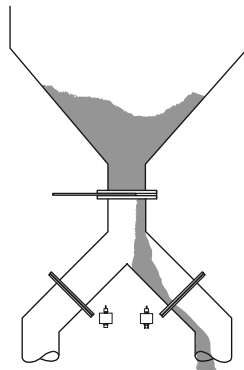

Leak Detection

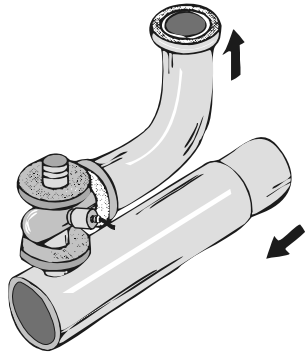
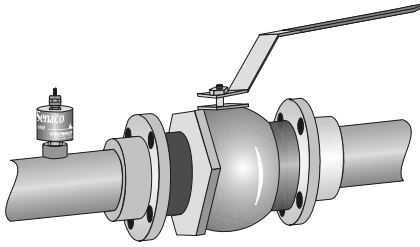

Cavitation Monitoring

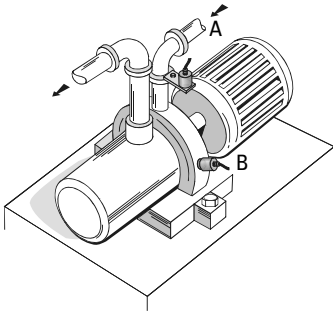

Install the SITRANS AS100 Sensor in either A or B locations.

Machine Condition Monitoring

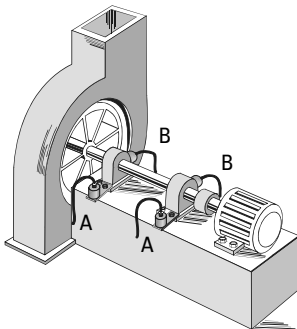

Install the SITRANS AS100 Sensor in either A or B locations.

Manufactured Date

To identify when the product was built use the tables below based on the serial number on the product.

Serial Number Scheme									
Company/ Plant code	Separator	Year of MFG.	Month of MFG.	Day of MFG.		4 digit sequential # (0000 to 9999)			
PBD	/	S	1	0	1	0	0	0	1
PBD	/	S	1	0	1	0	0	0	2
PBD	/	S	1	0	1	0	0	0	3

Refer to following tables for encoding formats.

Encoding of Letters

Year of Manufacture (one character alpha entry)										
Year	2000	2001	2002	2003	2004	2005	2006	2007	2008	2009
ALPHA CODE	M	N	P	R	S	T	U	V	W	X
Year	2010	2011	2012	2013	2014	2015	2016	2017	2018	2019
ALPHA CODE	A	B	C	D	E	F	H	J	K	L

Month of Manufacture (one character alpha or numeric entry)											
Jan.	Feb.	Mar.	Apr.	May	Jun.	Jul.	Aug.	Sept.	Oct.	Nov.	Dec.
1	2	3	4	5	6	7	8	9	O	N	D

Day of Manufacture (two character numerical entry)																			
01	02	03	04	05	06	07	08	09	10	11	12	13	14	15	16	17	18	19	20
21	22	23	24	25	26	27	28	29	30	31									

Index

A

Accessories 6
Accessory Mounting 9
Analog Output 13, 16
Applications 14
Approvals 3
AS100 (ATEX II 2GD version) 5
AS100 (Class II Rated ST and ET versions) 4
AS100 (ST and ET versions) 4
AS100 Standard Temperature Version (ST)
12
Avoid 7

C

Construction 2

D

Direct Mounting 8
Diverter Gate 14

E

Extended Temperature Version (ET) 12
Extension Tab 9

F

Features 1

G

General Information 1

I

Ideal Location 7
Ingress Protection 2
Installation 7
Interconnection 12

L

Leak Detection 15

M

Model 2
Mounting 8
Mounting Disc 9

O

Operating Temperature 2
Output 2

P

Pneumatic Conveyor 14
Power 2

R

Relative Sensitivity 13

S

Screw Conveyor Discharge 14
Solids Flow Sensing 7

Specifications 2

T

Temperature Considerations 11
The Senaco AS100 Sensor 1

W

Weight 2
wire gauges 13

Notes

For more information

www.siemens.com/level

www.siemens.com/weighing

Siemens AG
Industry Sector
1954 Technology Drive
P.O. Box 4225
Peterborough, ON
Canada K9J 7B1

email: techpubs.smpi@siemens.com

www.siemens.com/processautomation

Subject to change without prior notice
A5E31952194 Rev. AA

© Siemens AG 2013



A 5 E 3 1 9 5 2 1 9 4
Printed in Canada